

# AIR PREPARATION UNITS

## AIR FILTER series

Kushako

### Air Filter details :

#### Features :

- Suitable for modular mountings.
- Press type manual drain for easy operation.
- Bronze / Plastic sintered element .
- Separator & shield for efficient moisture separation.

#### Precautions :

- Note the direction of flow before installation & connect pipe accordingly.
- Nipples of taper threads to be used with teflon tape. Ensure teflon tape does not enter the unit during tightening. Nipples of straight threads to be used with sealing washer.
- Flush piping for dirt, dust, rust & other foreign particles.
- Install in clean atmosphere.
- Polycarbonate bowl may get damaged & possibly fail if exposed to synthetic oils, thinner, solvents, trichloroethylene, kerosene or other aromatic hydrocarbons.



#### Technical Specifications:

Model	AF-2012 (Eco)
Medium	Compressed air
Port Size	G1/4 BSP ( F )
Bowl capacity (ml)	15
Flow rate ( Ltr / Min )	800
Maximum supply pressure (bar)	10
Filtration (µm)	1, 5, 25, 40 ( standard ) , 50, 100
Bowl material	Polycarbonate
Ambient / Medium temperature	5° - 60° C
Installation	Vertical (As in the picture)
Materials of construction	Aluminium, Brass, Steel, SS, Nitrile
Optional accessories	Clamp, Modular mounting kit, Pr gauge
Weight (Kg)	0.103

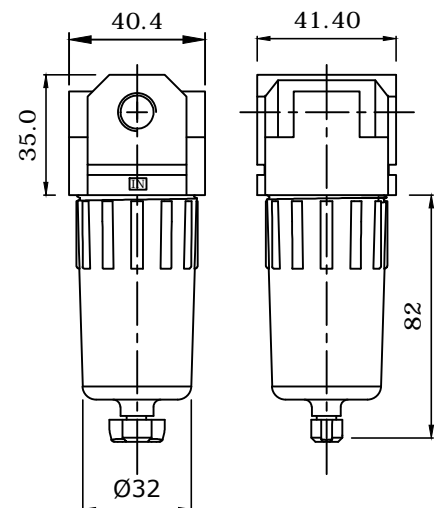

- Supply pressure 6 bar , pressure drop  $p = 0.3$  bar ( for standard models ).



Manufactured by :

**Kushako India**

Office : 490, Narayan Peth, Opp. Pune Marathi Granthalaya, Pune - 411030. (Maharashtra), Website : [www.kushakoindia.com](http://www.kushakoindia.com)

Works : Sr.No. 25/1A, Village Nanded, Sinhgad Road, Tal - Haveli, Dist. Pune -411041

Tel. No : 901169077 / 7620674777

E-mail : [kushako.india@gmail.com](mailto:kushako.india@gmail.com) / [kushakoindia1992@gmail.com](mailto:kushakoindia1992@gmail.com)

Kushako